

| REV. | ECN NO. | DESCRIPTION | SIGN | DATE |
|------|---------|-----------------|------|------------|
| D1 | N/A | INITIAL DRAWING | Peng | 2013/04/08 |

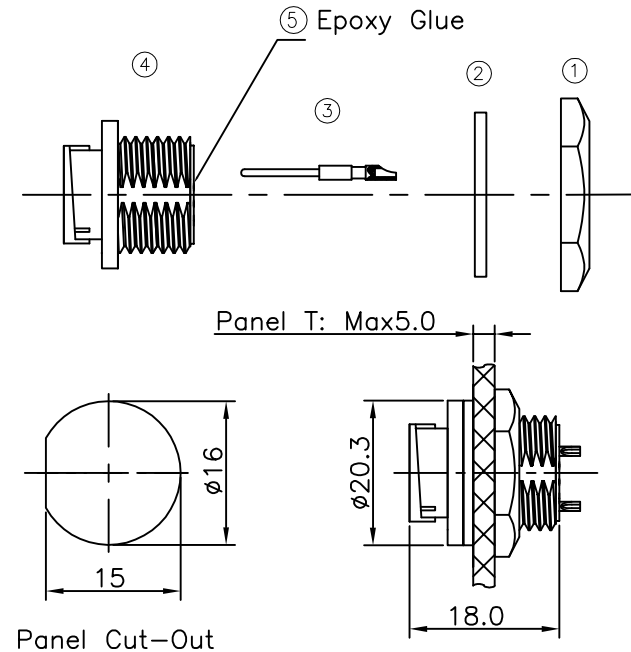

Table 1

| Position No. | Connector Part No. | 4 Housing Part No. | 3 Contact | | |
|--------------|--------------------|--------------------|------------------|------|---------------------|
| | | | Contact Part No. | Q'ty | Contact Description |
| 2 | 22002525-03 | 105-00068-00 | 301-00068-02 | 2 | MZP1.5 |
| 3 | 22003525-03 | 105-00076-00 | 301-00068-02 | 3 | MZP1.5 |
| 4 | 22004525-03 | 105-00087-00 | 301-00068-02 | 4 | MZP1.5 |
| 5 | 22005525-03 | 105-00092-00 | 301-00052-02 | 5 | MZBP1.0 |
| 6 | 22006525-03 | 105-00098-00 | 301-00052-02 | 6 | MZBP1.0 |
| 2+4 | 22204525-03 | 105-00274-00 | 301-00068-02 | 2 | MZP1.5 |
| | | | 301-00052-02 | 4 | MZBP1.0 |
| 3+4 | 22304525-03 | 105-00211-00 | 301-00068-02 | 3 | MZP1.5 |
| | | | 301-00067-02 | 4 | MZP0.8 |
| 8 | 22008525-03 | 105-00102-00 | 301-00052-02 | 8 | MZBP1.0 |
| 10 | 22010525-03 | 105-00107-00 | 301-00067-02 | 10 | MZP0.8 |
| 12 | 22012525-03 | 105-00111-00 | 301-00067-02 | 12 | MZP0.8 |

Table 2 (Hole Arrangement, Mating Face)

| | | | | |
|----------------|----------------|---------------|-------------|-------------|
| | | | | |
| 2 Pos | 3 Pos | 4 Pos | 5 Pos | 6 Pos |
| 300 v 10 A | 300 v 10 A | 125 v 10 A | 60 v 5 A | 60 v 5 A |
| | | | | |
| (2+4)Pos | (3+4)Pos | 8 Pos | 10 Pos | 12 Pos |
| 60 v 10+5 A | 60 v 10+2 A | 60 v 5 A | 30 v 2 A | 30 v 2 A |

Specification:

- 1.Operation temperature:-45°C~105°C.
- 2.Insulation resistance:100MΩ at DC500V.
- 3.Contact resistance:<10mΩ.
- 4.Waterproof:IP67.
- 5.RoHS compliant.
- 6.Mating Waterproof Cap P/N:806-00031-00.
- 7.Mating Connector P/N:22XXX221-XX or 22XXX223-XX-001 or 22XXX224-XX-001.

Material List

| No. | Material No. | Q'ty | Material Description | Remark |
|-----|-------------------|------|-------------------------|--------|
| 1 | 112-00007-00 | 1 | Standard Panel Nut | |
| 2 | 503-00018-00 | 1 | Standard Gasket | |
| 3 | See above table 1 | | Contact | |
| 4 | See above table 1 | 1 | Standard-XX Pos Housing | |

UNIT:mm

Description: Standard Series Rear Mount, Lock Type, Pin Solder

TOLERANCE: .X ±0.25, .XX ±0.15, .XXX ±0.05, ANGLES ±1°

SCALE: N/A SHEET 1 OF 1

REV. D1 SIZE A4 :Inspection Item

CHOGORI USA Inc.

| | | | | | |
|----------|-------------|-------------|------|------|------------|
| PART NO | 22XXX525-03 | DRAWN BY | PENG | DATE | 2013-04-08 |
| DWG NO | | CHECKED BY | | DATE | |
| CUSTOMER | | APPROVED BY | | DATE | |

THIS INFORMATION IS CONFIDENTIAL AND IS DISCLOSED TO YOU ON CONDITION THAT NO FURTHER DISCLOSURE IS MADE BY YOU TO OTHER THAN CHOGORI PERSONNEL WITHOUT AUTHORIZATION FROM CHOGORI CORP.